

IT Guida Installazione per collegamento cavo con chiavetta Wi-Fi B1020 per unità interne Cassette

EN Installation guide for cable connection with B1020 Wi-Fi for cassette indoor units

FR Guide d'installation pour le raccordement du câble avec clé Wi-Fi B1020 pour unités intérieures Cassettes

DE Installationsanleitung für Kabelanschluss mit WLAN-Stick B1020 für Innengeräte Kassetten

ES Guía de instalación para la conexión del cable con la llave Wi-Fi B1020 para unidades internas Cassette



Installare il kit Wireless

- 1) Rimuovere il tappo protettivo e connetterlo al cavo



- 2) Dopo aver assemblato il modulo Wireless secondo le istruzioni installare il modulo wireless nella posizione di aggancio del pannello, come mostrato nell'illustrazione.

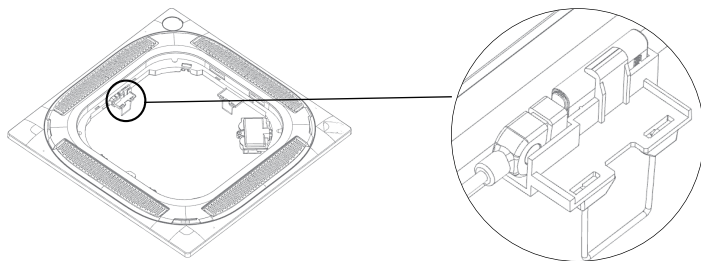

Pannello frontale

3) Collegare il cavo del kit alla porta wireless CN 38 della scheda elettronica, chiudere il coperchio della scheda e installare il pannello estetico.

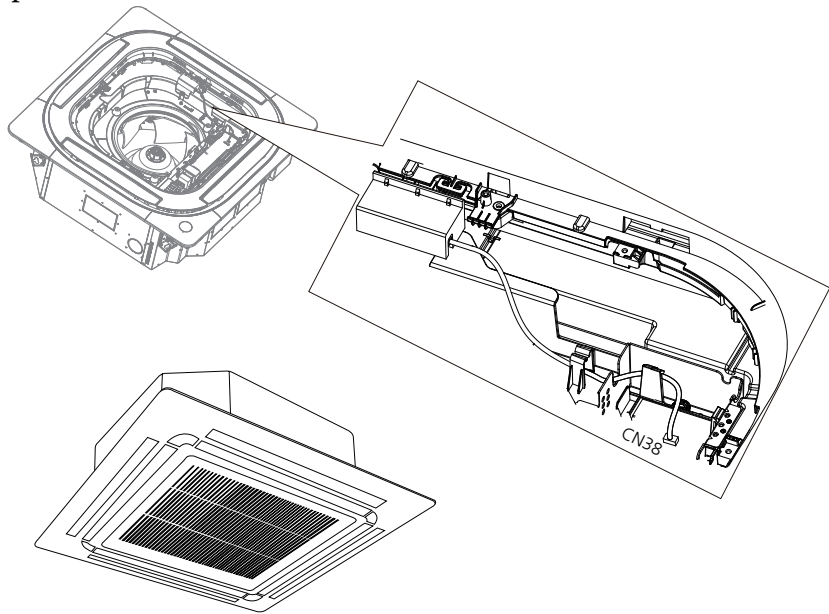

Install the wireless kit

- 1) Remove the protective cap of the kit, connect with the connection wire.

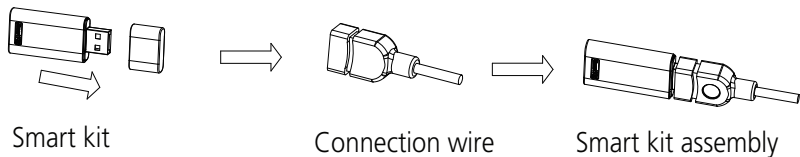

- 2) After assembling the Wireless module according to the first step, install the Wireless module into the panel snap position as shown in the illustration.

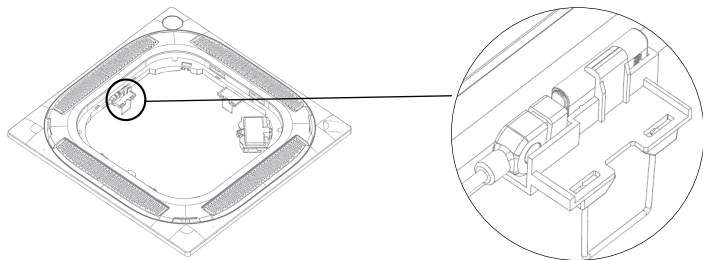

Front panel

- 3) Connect the wire of the kit assembly to CN 38 Wireless port of the main board, then install the electrical control cover and the aesthetic panel.

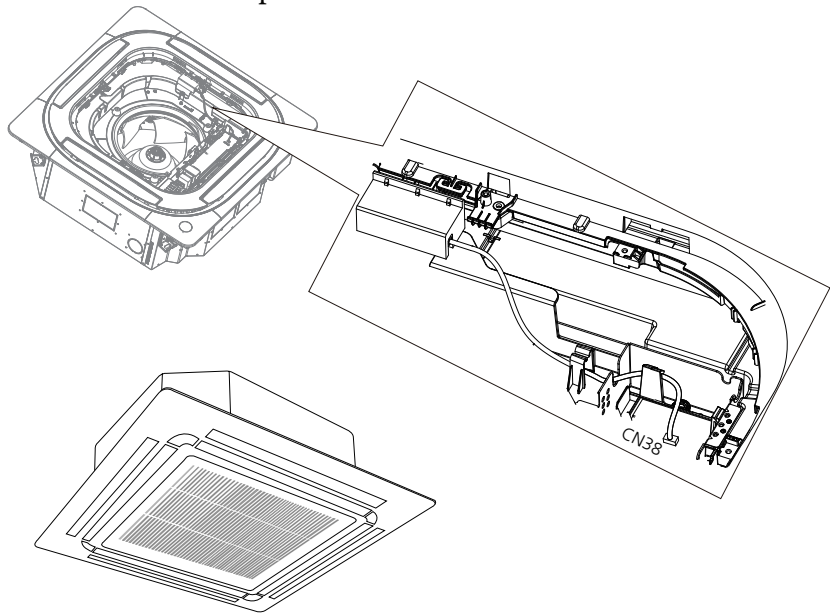

Installer le kit sans fil

- 1) Retirez le capuchon de protection et connectez-le au câble.

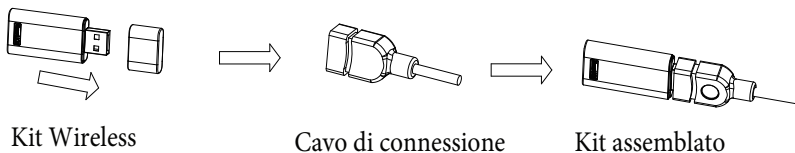

- 2) Après avoir assemblé le module sans fil conformément aux instructions, installez-le dans son emplacement d'accueil sur le panneau, comme indiqué sur l'illustration.

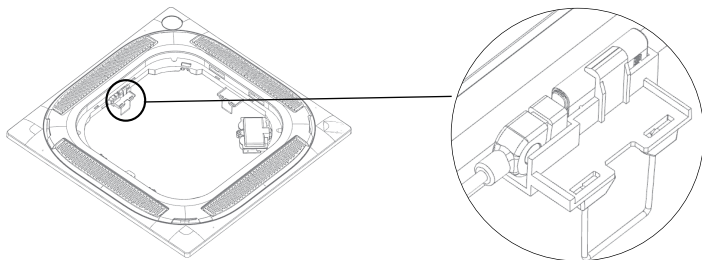

Panneau avant

3) Connectez le câble du kit au port sans fil CN 38 de la carte mère, puis installez le couvercle et la grille de commande électrique.

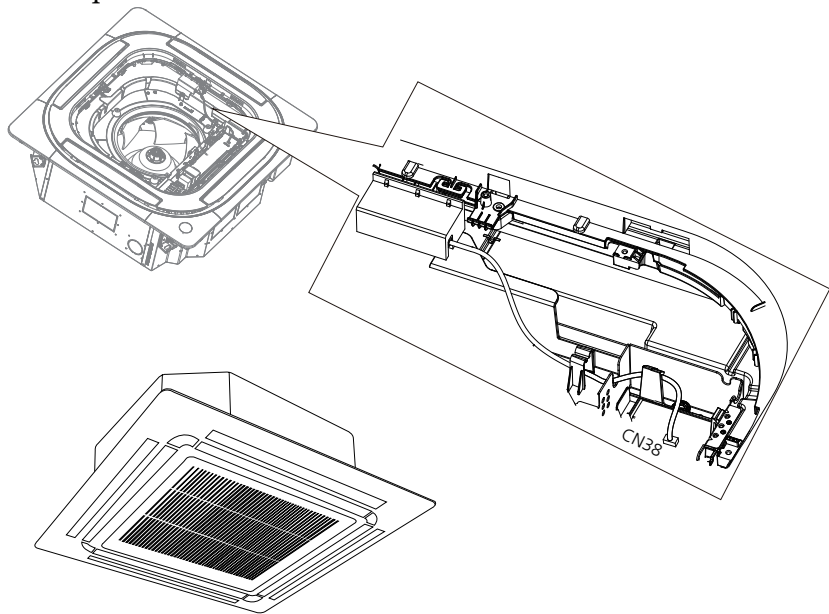

Installieren Sie das drahtlose Kit

1) Entfernen Sie die Schutzkappe und schließen Sie das Kabel an.

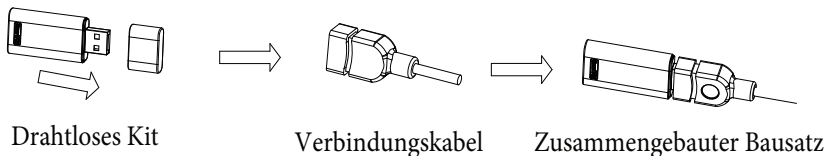

2) Nachdem Sie das Modul ohne Verkabelung gemäß der Anleitung zusammengebaut haben, installieren Sie es wie in der Abbildung gezeigt im Ablagefach an der Frontplatte.

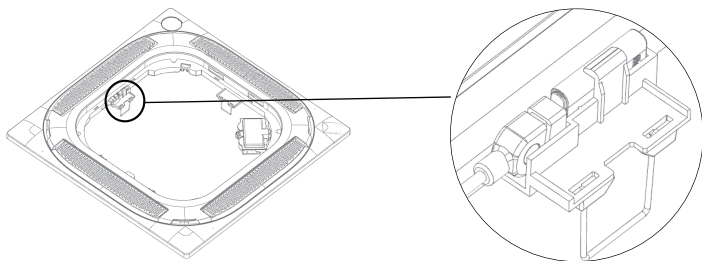

3) Schließen Sie das Kit-Kabel an den CN 38 Wireless-Anschluss auf dem Motherboard an und montieren Sie anschließend die Abdeckung und das elektrische Steuerungsgitter.

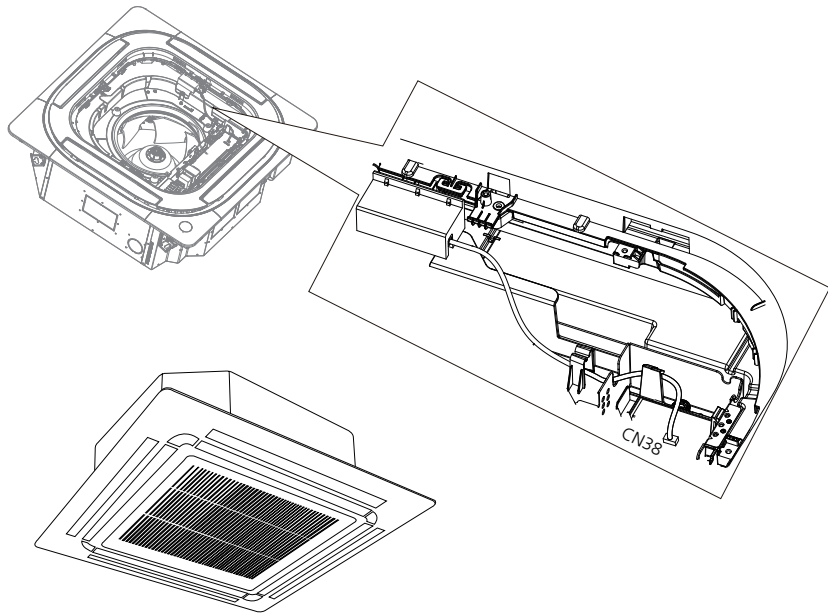

Instalar el kit inalámbrico

1) Retire la tapa protectora y conecte el cable.

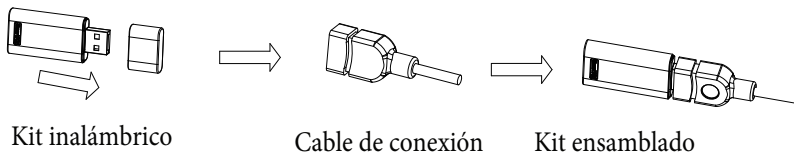

2) Después de ensamblar el módulo sin cableado según las instrucciones, instálelo en el compartimiento de almacenamiento en el panel frontal como se muestra en la ilustración.

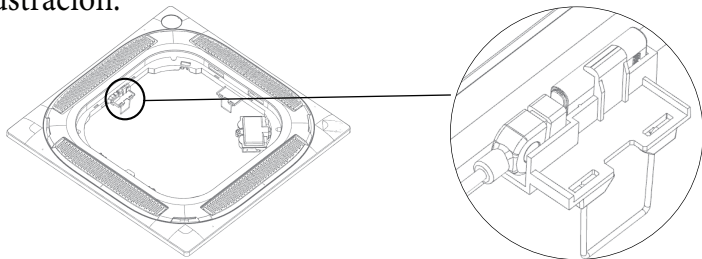

panel frontal

3) Conecte el cable del kit al conector inalámbrico CN 38 en la placa base, luego instale la cubierta y la rejilla de control eléctrico..

